



AC4 CS-LSA

Economical



www.lightwing.ch

Lightwing AC4 CS-LSA: The Swiss Sport Utility Aircraft

The European Light Sport Aircraft Lightwing AC4 CS-LSA is an economical two-seat aircraft for pilot training. It is equipped with the modern, reliable and economic fuel injection engine.

Proven and stable design

- Anodised Aluminium components, cladding is made of durable CFRP/GRP
- Robust landing gear for all different runways
- Strong and reliable hydraulic Beringer Brakes
- Comfortable cabine width of 1.26 m
- Spacious, good accessible luggage compartment
- 216 kg payload

Water-cooled Injection engine

- Reliable startup at every temperature
- No carburetor icing
- Optimized lean at all time
- Environmentally friendly with 14 l/h at 165 km/h
- 6 h Endurance with 90 Liter Fuel
- Pleasantly quiet with 65 dB(A)
- MOGAS instead of AVGAS, approx 25 % cost saving
- Highest operation reliability

Safe flying characteristics

- Take off roll distance of 138 m at MTOW
- Spinresistent, easy to master, safe stall behaviour
- Simple operation
- Perfect for flight training and group operation
- Precise control with direct controlled nose wheel
- Perfect view

State of the art Avionics

- Dynon Skyview with analogue or EFIS display at a finger tip
- Vector-, Pixelmap, Approach- and Groundmaps
- Traffic information on map and in synthetic vision
- WLAN connection with Easy VFR / ForeFlight / FF / Skydemon / Sky-Map for flight plan
- Digital engine monitoring unit
 - Status LANE A & B
 - EGT and CHT on all Cylinders
 - Throttle position in %

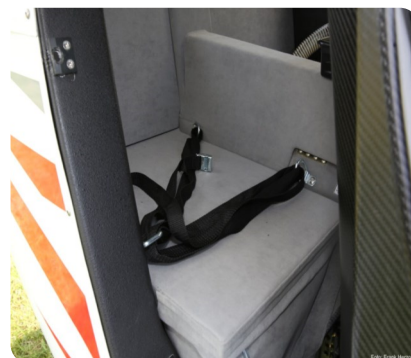

Lightwing AC4 CS-LSA — Technical Data

- High strutted wing, 2 Seats
- Anodised aluminium structure
- Polyester laminated for wings and control surfaces
- 100 HP 4 valve engine Rotax 912iS Sport with redundant electronic fuel injection
- 3-blade propeller Neuform
- Type Certificate: CS-LSA EASA.A.588
- Generous glazing for good visibility
- Licence PPL or LAPL

Speed/Performance	Metric	Standard
Stallspeed Flaps 24°	V _{S0} 76 km/h	41 KIAS
Stallspeed Flaps 0°	V _{S1} 82 km/h	44 KIAS
Flapspeed	V _{FE} 165 km/h	89 KIAS
Maximum speed IAS	V _{NE} 210 km/h	113 KIAS
Manouvering Speed	V _A 176 km/h	95 KIAS
Climb rate at MTOW	4.4 m/s	876 ft/min
Best climb angle	V _X 108 km/h	58 KIAS
Roll distance	138 m	452 ft
Take off distance over 15m/50ft	276 m	905 ft
Load factor	+4/-2g	+4/-2g

Weights

Maximum take-off weight	600 kg	1'389 lbs
Maximum payload	216 kg	470 lbs
Fuel tank capacity (flyable)	90 l	24 gal
Fuel consumption	14 l/h	3.73 gal/h
Baggage compartment Volume	550 Liter	19.4 ft ³
Baggage Weight	2 x 25 kg	2 x 55 lbs

Dimension

Wing span	9.57 m	31.4 ft
Total length	6.95 m	22 ft
Maximum height	2.67 m	8.76 ft
Kabinenbreite	1.26 m	4.13 ft
Tyre front gear	4.00-6"	4.00-6"
Tyre main gear	15x6.00-6"	15x6.00-6"

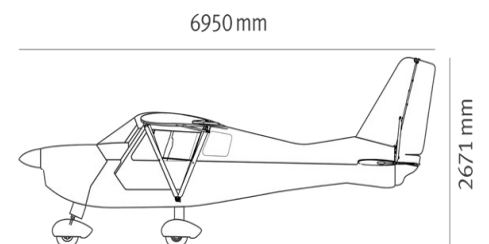
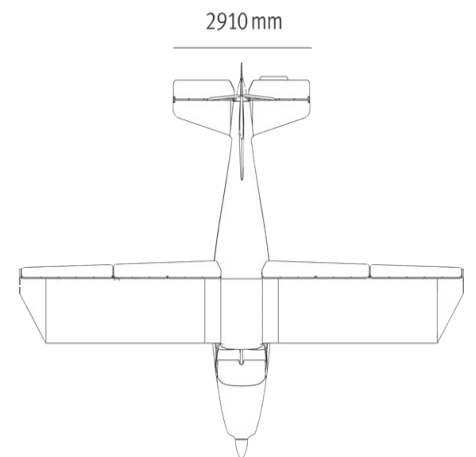
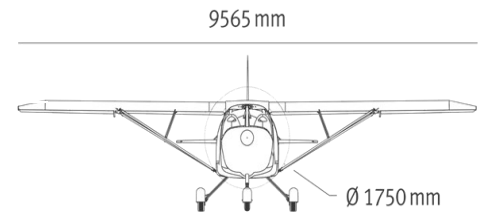

Spacious, safe, rugged, economical



Light Wing AG, Riedenmatt 1, CH-6370 Stans info@lightwing.ch